



**HODEL
BETRIEBE**

Grue compacte C52



Grue sur chenilles flexible avec Effer 525

- Scanreco Télécommande avec display
- Progress 2.0
- Moteur diesel Tier 5
- acier chenilles en caoutchouc
- Moteur électrique 380V / 15KW avec inverseur
- Plate-form EN 280
- PSAgA



Êtes-vous intéressé?



**Consultation
et conception**

*Chez nous, vous êtes
entre de bonnes mains*

**Grues de chargement et
construction de véhicules spéciaux**

Hodel Betriebe AG • Mooshof 2 • CH-6022 Grosswangen • 041 984 06 00

Grue compacte C52

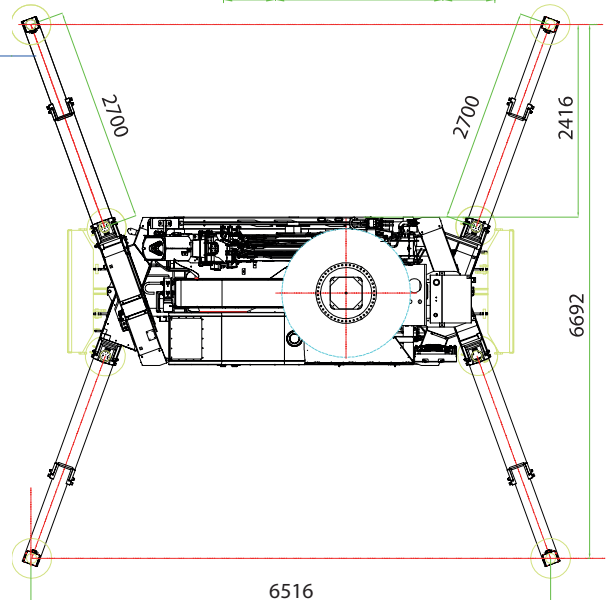
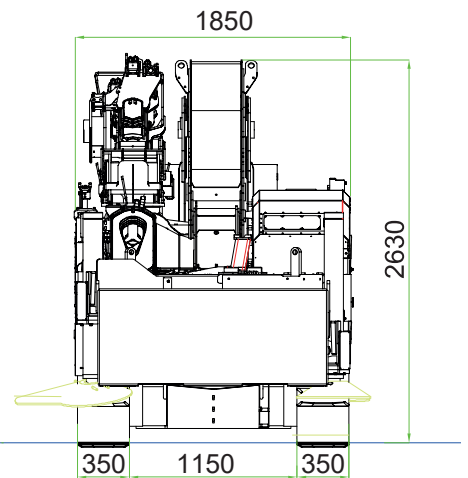
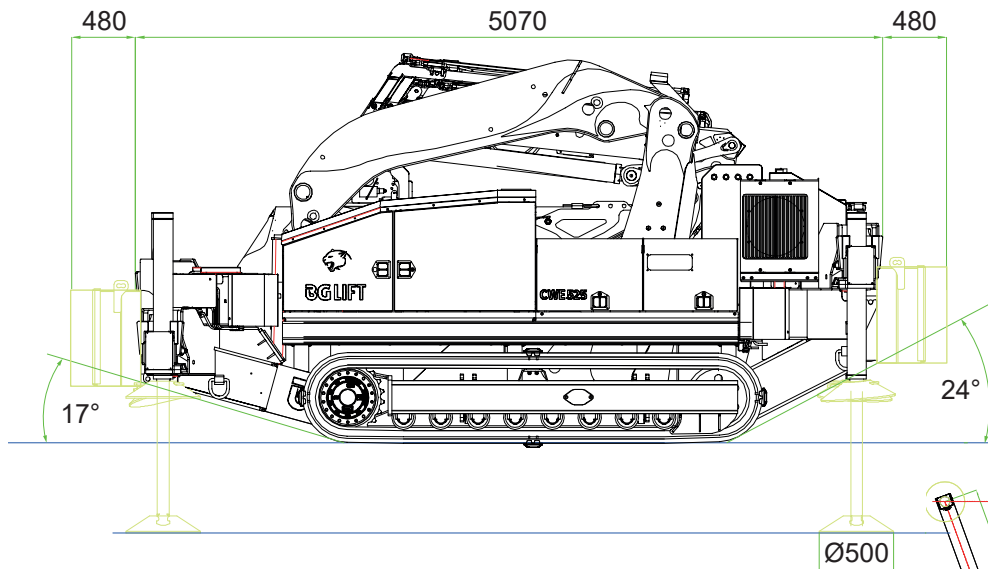
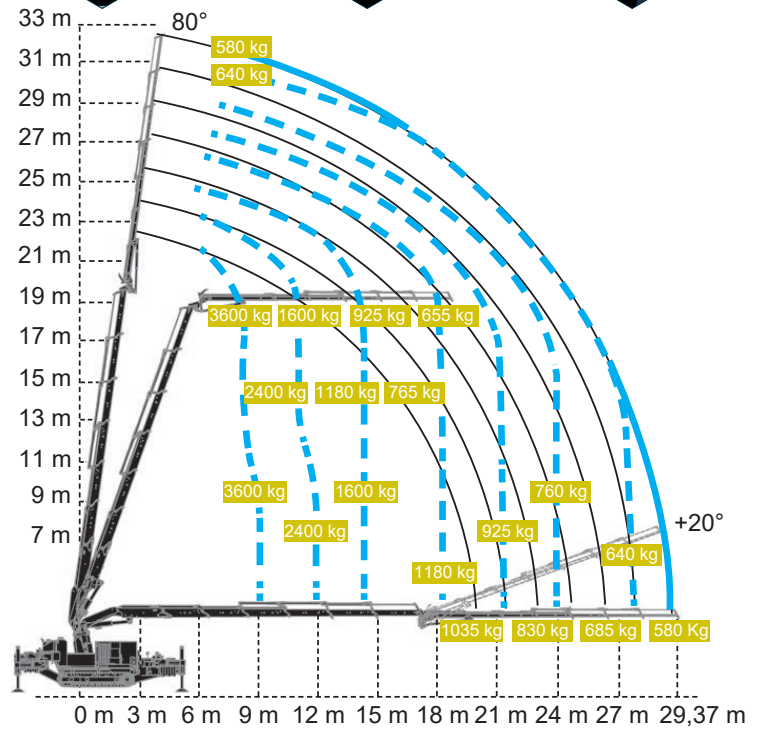
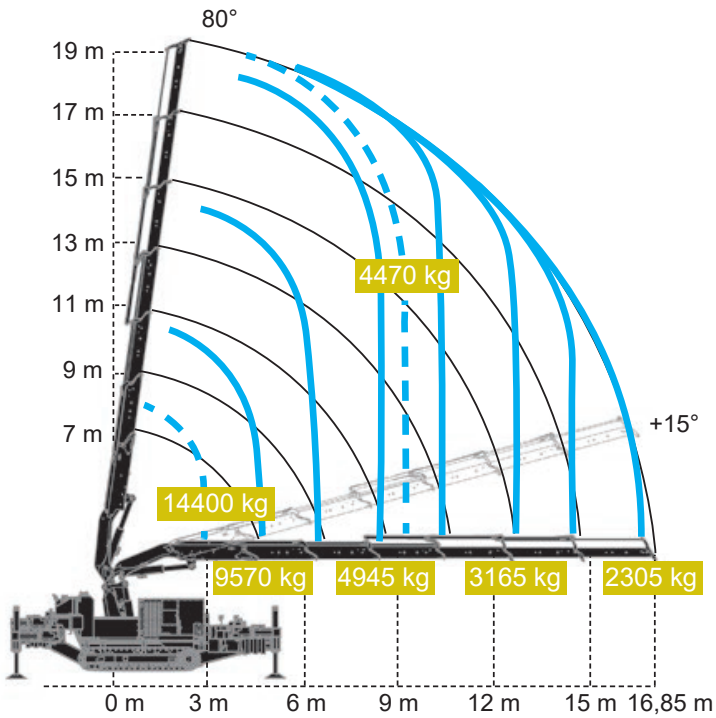

Fiche Technique

Gamme pivotante	sans fin
Treuil	1'900 / 2'500 kg
Moteur diesel	Yanmar 55 Kw / 291 Nm
Vitesse de conduite	1,2 / 2,2 km/h
Capacité de pente maximale	24°

Poids

grue de base	14'200 kg
Jib	1'200 kg
Contrepoids	2 x 1'800 kg
Poids total	19'000 kg
boîte de rangement	2 x 160 kg